



Sea-R.O.
WATERMAKERS

MAKING WATER BETTER, MAKING BETTER WATER

SEA-R.O., WATERMAKERS TEL: 954-527-5282 FAX: 954-462-7183

www.makeh2o.com

Amphibian 500-2000 Gallon Per Day Modular Desalination System with I-Control and remote display/controller or tank level float control

Full featured system features I-Control system controller and remote control to make system operation as simple and automatic as possible. Controller provides constant reading of water quality, temperature and hourmeter. Automatic fresh water flush is activated at end of every running cycle to maintain best possible membrane performance and extend the life of membranes and all system components. All commercial duty components are used throughout design to provide a rugged and reliable system for larger vessels both commercial and private yachts.

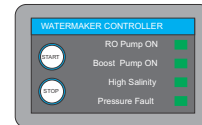
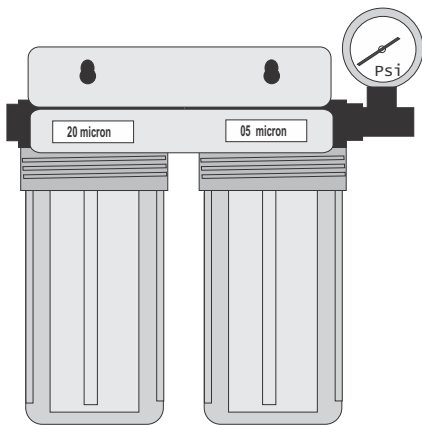

Choose from either remote control panel or tank level float switch

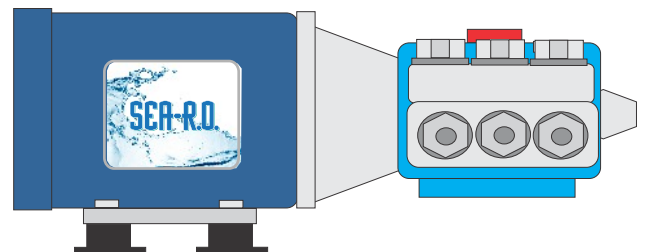
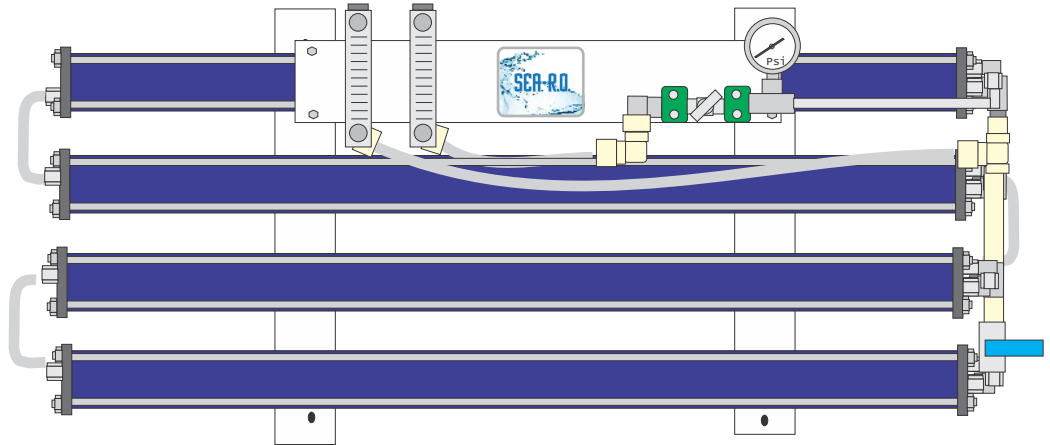
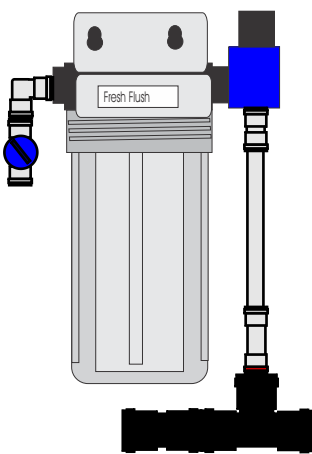

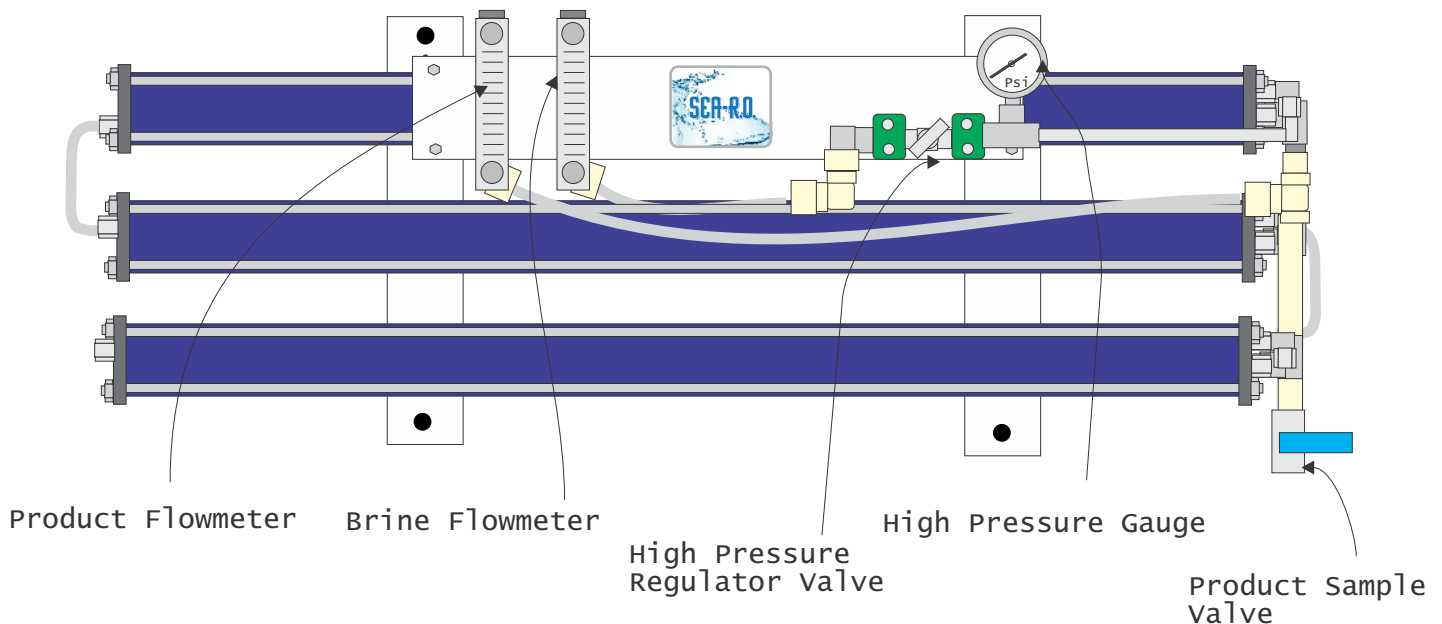

“Amphibian” Series Membrane And Pressure Vessel Assembly

Pressure vessel is all fiberglass construction, 1000 psi rated. Simplified end cap design is rugged and easy to service with no special tools required, pressure and product ports are 316 SS with o-ring seals that allow fittings to swivel and eliminate stress on end cap material. Industry standard membrane size is available worldwide.

Mounting brackets are predrilled and allow easy attachment to bulkhead or wall, overhead mounting is possible with additional “L” brackets

Product flowmeter reads .1 to 1 gpm, stainless steel float and removable top cap for easy disassembly and cleaning. Outlet of flowmeter has dual attachment of either 1/4” FNPT or 1/2” MNPT for easy plumbing to storage tank.

Brine flowmeter has same features as above product flowmeter, with 0-5 gpm range. Plumb directly overboard or to a drain.

High pressure regulator valve is all 316 SS and is securely mounted to panel. Tee type handle allows precise pressure adjustment with no tools.

High pressure gauge has all 316 SS internals and is glycerine filled to provide accurate and steady pressure reading.

High pressure piping is 316 SS with positive sealing nut and ferrule connections.

Low pressure piping is flexible nylon tubing with nut and o-ring connections for leak free operation.

Simple Product Water Sample valve is included to allow easy sampling of product water before sending to storage tank. This also is a handy method of filling a container for supply of chilled drinking water in your refrigerator that is directly from the membrane.

High pressure hose connects to pump with industry standard 316 SS flare fittings with reusable type ends, allowing field replacement of hose with common tools and no swaging.

Dual prefiltration system

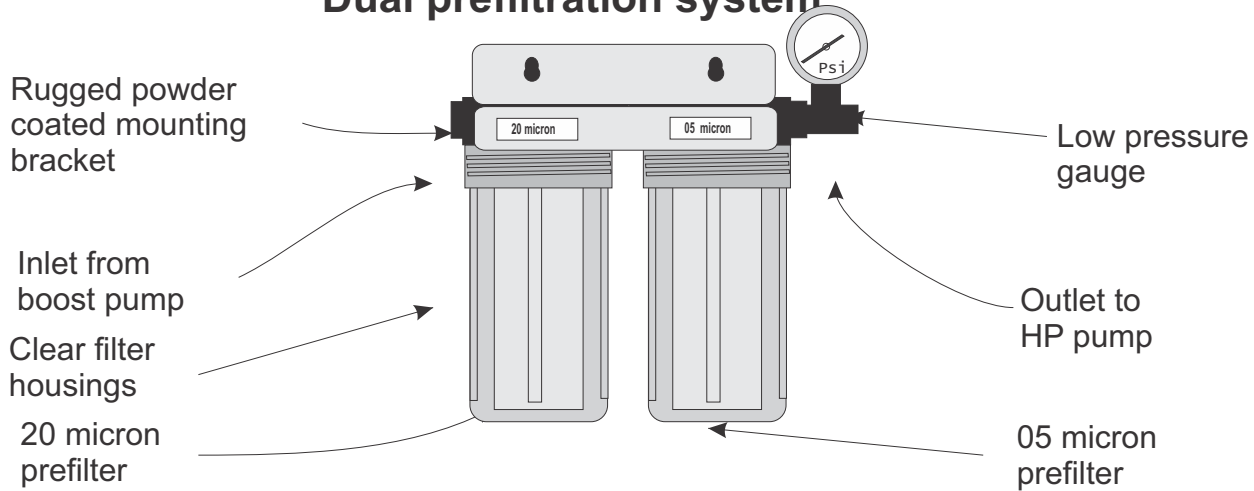

5" x 10" FDA approved polypropylene housings are heavy duty industrial rated at 125 psi. O-ring sealed to provide leak free operation. Standard 3/4" FNPT inlet and outlet.

Heavy Duty mounting bracket allows easy mounting. Filter wrench included

Low pressure gauge monitors filter performance and indicates when service is required. 316SS and glycerine filled.

Dual 20 and 05 micron filter cartridges provide optimum sediment and particle removal. 100% poly media permits cleaning several times before replacement. Industry standard 3x10" size.

Auto Fresh water flush system

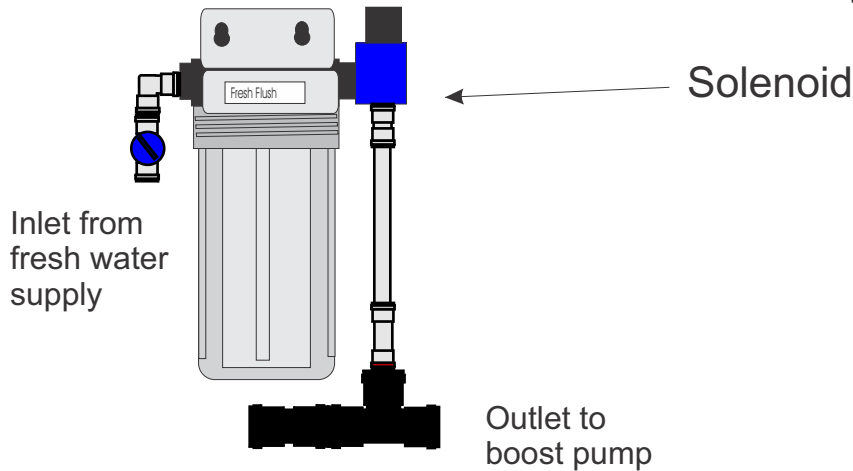

Auto Flush option flushes system on every shut down with de-chlorinated fresh water to purge sea water from system and greatly extend membrane performance.

Clear FDA approved polypropylene housing is heavy duty industrial rated at 125 psi. O-ring sealed to provide leak free operation, standard 3/4" FNPT inlet and outlet.

Two way solenoid valve allows simple change over from normal to flushing mode.

Solid block carbon filter removes chlorine from fresh water supply, providing flush water without any negative affect on membrane. This also allows production of ultrapure water for battery filling,

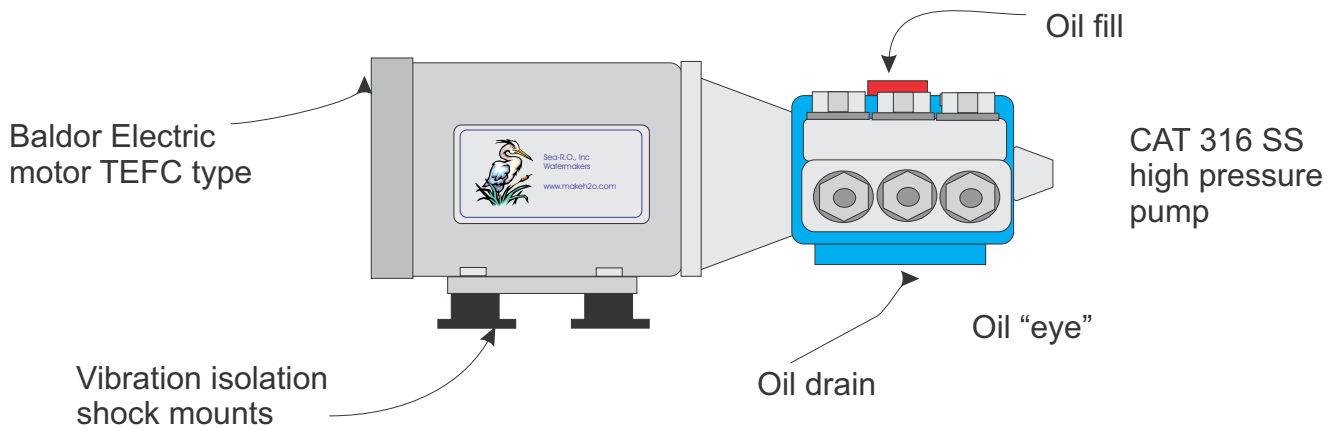

High pressure pump and motor assembly

CAT 316 SS high pressure pump is a ceramic plunger design for long life and proven performance in seawater. CAT pumps are the longest lasting, most trouble free pumps available, service and parts distribution available worldwide and the simple design allows easy routine service without any special tools.

Pump has an oil filled crankcase with easy access to drain and fill. Unique oil "eye" allows oil level to be checked with a glance. No drips or dipsticks necessary.

Industry standard WEG motor is the best, most efficient motor available. Service is almost never required, but if so, WEG has an outstanding worldwide network of agents and service centers.

Pump and motor are smooth and quiet by design, and yet we go one step to further dampen any noise and vibration with flexible mounts. These also elevate the pump and motor to allow cleaning beneath the assembly.

Control panel provides total motor and pump protection from low voltage, low or high pressure, or improper operation.

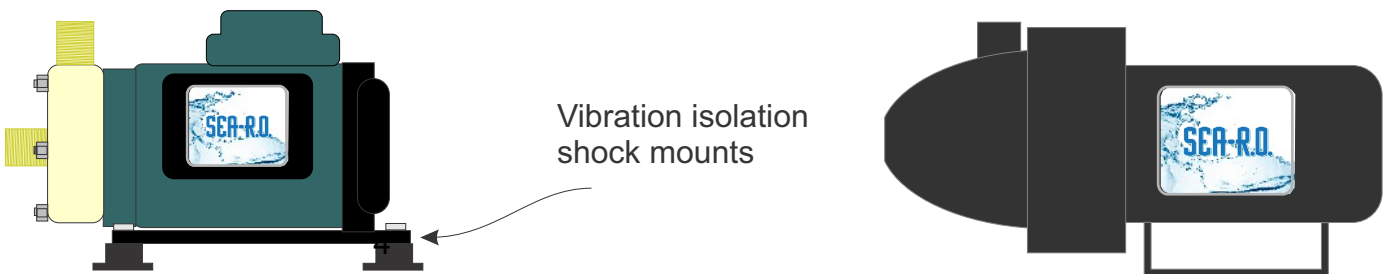

Boost pump and motor assembly

High Head magnetic drive poly pump close coupled to 3450 RPM 385 Watt motor provides 20-25 psi of boost pressure for optimum filter life. No mechanical seal to ever require servicing. Vibration isolation mounts to eliminate noise and elevate assembly.

Pump is protected by control panel from dry running or low voltage

Choose from Magnetic Drive centrifugal design for boat installations or shallow well jet for land based units with up to 20' suction lift. Shallow well type does have conventional mechanical seal and includes foot valve for well

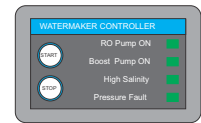
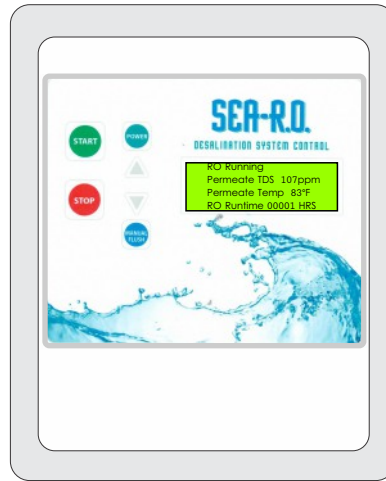
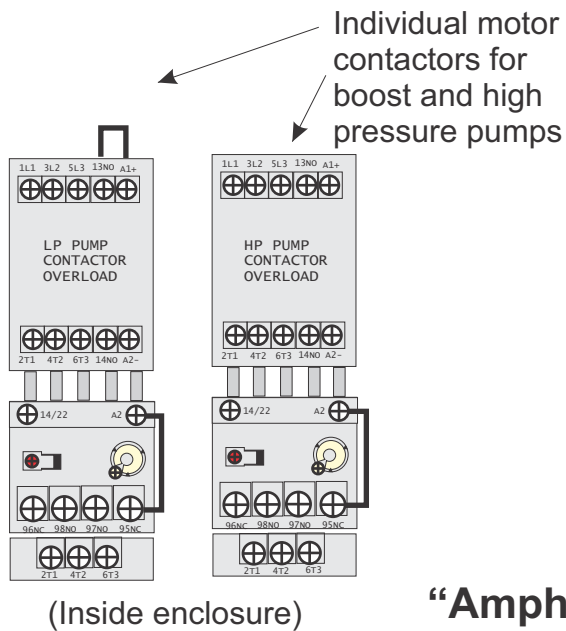

Remote Control with 50' cable or Float Switch

“Amphibian” System Control Panel with I-Control and remote control or float switch

System control panel provides complete operation and protection of all other system components. Rugged electrical components are housed inside a NEMA 4X rated enclosure which can tolerate splashing, washdowns, and the corrosive environment where watermakers are used.

Sequential starting of boost pump for 60 seconds before high pressure pump provides thorough pre-flush of system and reduces the starting amperage for optimum energy efficiency

Resettable overloads will safely shut system down if supply voltage is too low. This can occur on boat electrical systems, marinas, and islands.

Safety shut down switch for low pressure prevent any damage to components if the system is starved for water from a blocked inlet.

High pressure switch protects system from any possible operator error.

Liquid-tight flex fittings are used on power supply, high pressure pump, and boost pump umbilical cables. These fittings prevent strain and chafe on cables where they enter control panel and motors.

10 foot leads are provided as standard. Longer lengths are available for an additional charge, or may be added in the field by installer. Multi-strand, tinned copper wire in round gray protective sheath (boat cable) is standard. High pressure pump and boost pump are pre-wired.. You only need to connect the power supply.

Complete wiring diagram is provided for installation and operation.

Water Quality Monitor is factory preset to divert to drain any water that is produced that is over USEPA standards of 500 ppm. Display has constant read out of water quality, water temperature, and hourmeter

Remote control is easy to install with only one hole to drill and is surface mounted. Includes 50' cable with longer lengths available. Indicators for RO Pump ON, Boost Pump ON and alarms for High Salinity and Pressure Fault.

Float switch option with 50' cable controls system from tank level and is infinitely adjustable for on and off levels in your particular tank. Land Based only.